

Remote Rectifier Plus Datasheet

1. Description:

Large Battery banks (especially Lithium batteries) place a heavy demand on an alternator, with the potential for significant heat build-up which in turn reduces output and can damage the alternator. As a solution ElectroMaax offers a remote rectifier for the **GenMaax** and **Cruiser** alternators 250 Amp & 170 - 12 V and 165 & 80 Amp- 24 V models to address this condition.

Remote rectification has been in use for decades in industrial applications to eliminate the heat build-up in an alternator due to the rectification (AC to DC conversion) process. The advent of advanced battery technologies such as; LiFePO4 , super A.G.M and Carbon Foam have placed even higher demands on the alternator with resulting higher heat loads.; remote rectifiers minimize these issues.

Removing the internal rectifier from the **GenMaax** and **Cruiser** alternators and replacing it remotely, has multiple benefits including improved air flow through the alternator and elimination of a significant heat source.

The *ElectroMaax Remote Rectifiers* are pre-wired to the alternator requiring only primary DC positive / negative connections, ignition power input and tachometer output. The robust design consisting of an oversized heat-sink and cooling fan ensures both the alternator and the rectifier receive optimal cooling. Models are available for both 12 Volt and 24 Volt systems.

2. Specifications

Parameter	Value	Units
Capacity- output	250 @ 12 VDC or 165 @ 24 VDC	Amps
Temperature Range	-40 to 305 (-40 to 150 °C)	°F
Rectification	Solid State	
Cooling	Cross flow Forced air fan	



Remote Rectifier Plus Datasheet

3. Electrical Connections:

The rectifier has primary connections for the AC and DC components and secondary or control connections for interfacing with the vessel's ignition system. The AC cable length is 6 ft. (1.9 m)

NOTE: All electrical connections should be supported (restrained) to eliminate any mechanical strain on the connection lug.

Primary:

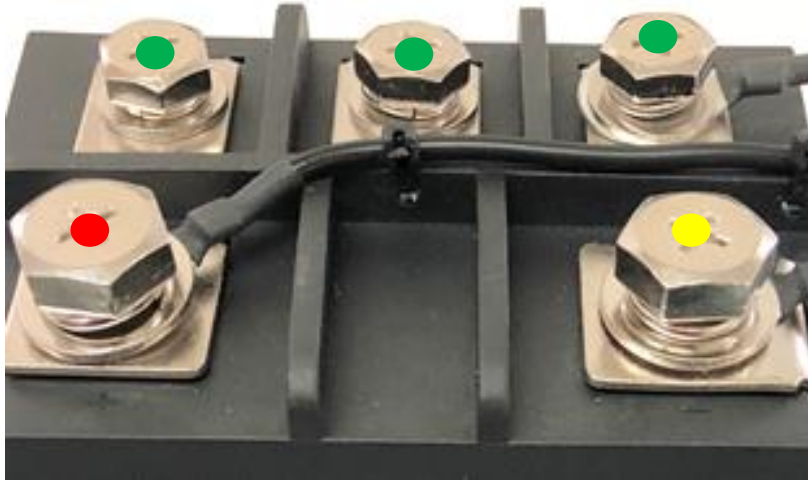

The AC connections are shown as ● and the DC as (positive) ● and (negative) ●

The AC connections configurations are not position critical, whereas the DC must be polarity correct.

NOTE:

N-type alternators will require a 12 VDC supply to the B+ post of the alternator. The wire size should be capable of 20 amp current (12-14 Ga) .

P-type alternators required a dedicated ground (12-14 Ga) for the Field circuit; which is be connected to unlabeled post ("Field Type" post – as per alternator manual)

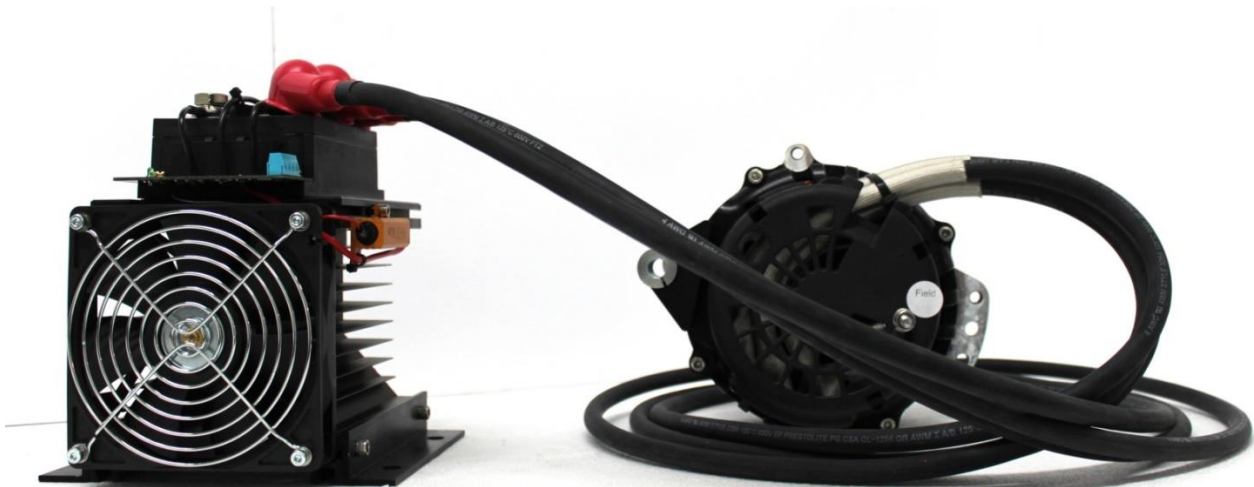

Remote Rectifier Plus Datasheet

Secondary:

The control connections are made to the blue terminal block on the connection panel (shown below) adjacent to the primary connections.

The following connections are;

W - Tachometer output

IG - Ignition signal IN

IG - Ignition signal OUT (optional use)

D+ - Warning Light (Current sink)

Note: Igniton IN & OUT can be in either position. This connection only montiors the ignition status and acts as a pass-thru.



LED:

A green LED is provided to indicate device status....once the DC connections are made (and powered) the LED will flash slowly, it will flash fast whenever the cooling fan is running.

FAN:

The cooling fan is ignition signal controlled, running for 10 minutes after the igniton signal ends.

Remote Rectifier Plus Datasheet

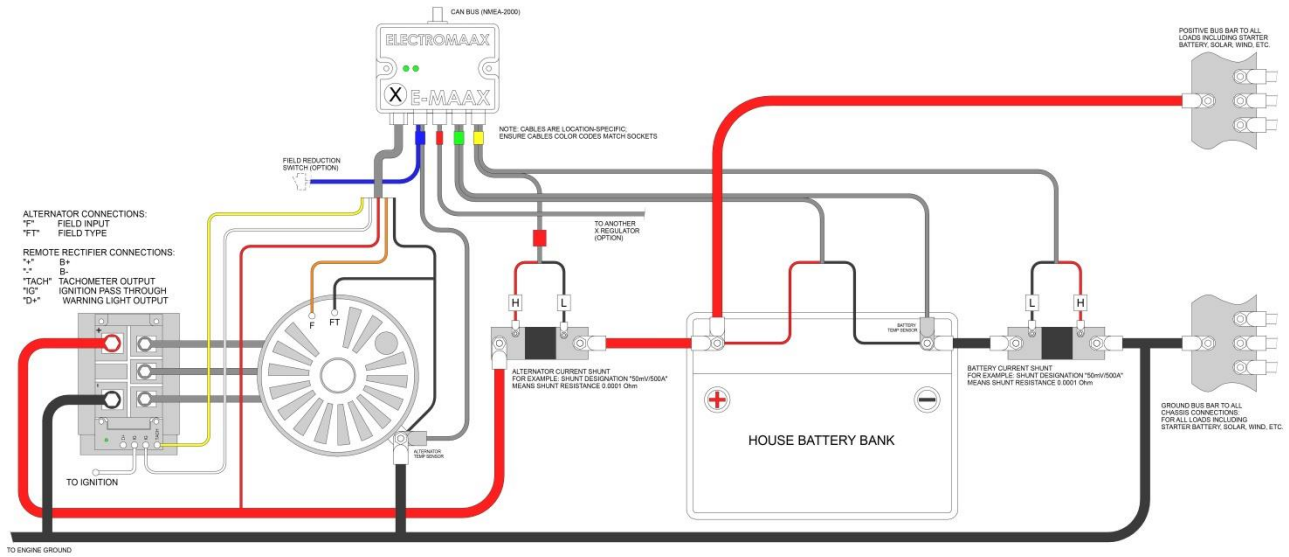

MOUNTING:

4 mounting holes are provided in the foot brackets on the heat-sink. The holes are 6.5 mm (¼") diameter on 90 mm (3.54") centers.

Dimensions:

The Rectifier is 180 mm (7.1") long x 176 mm (6.9") wide and 180 mm (7.1") high.

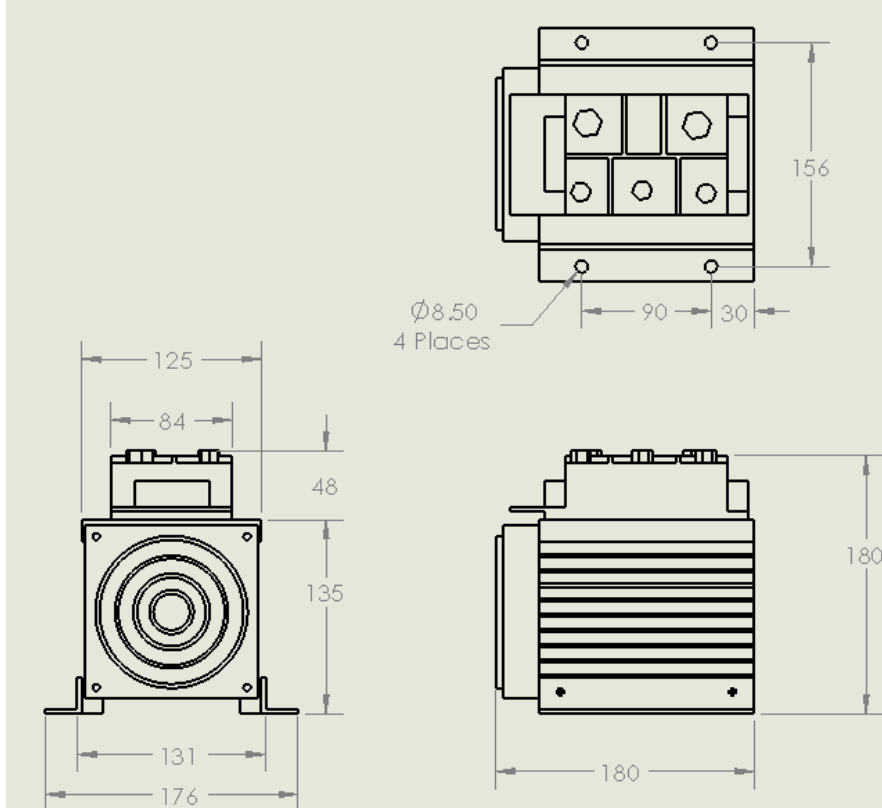

Remote Rectifier Plus Datasheet

Mounting holes footprint (mm) shown below.

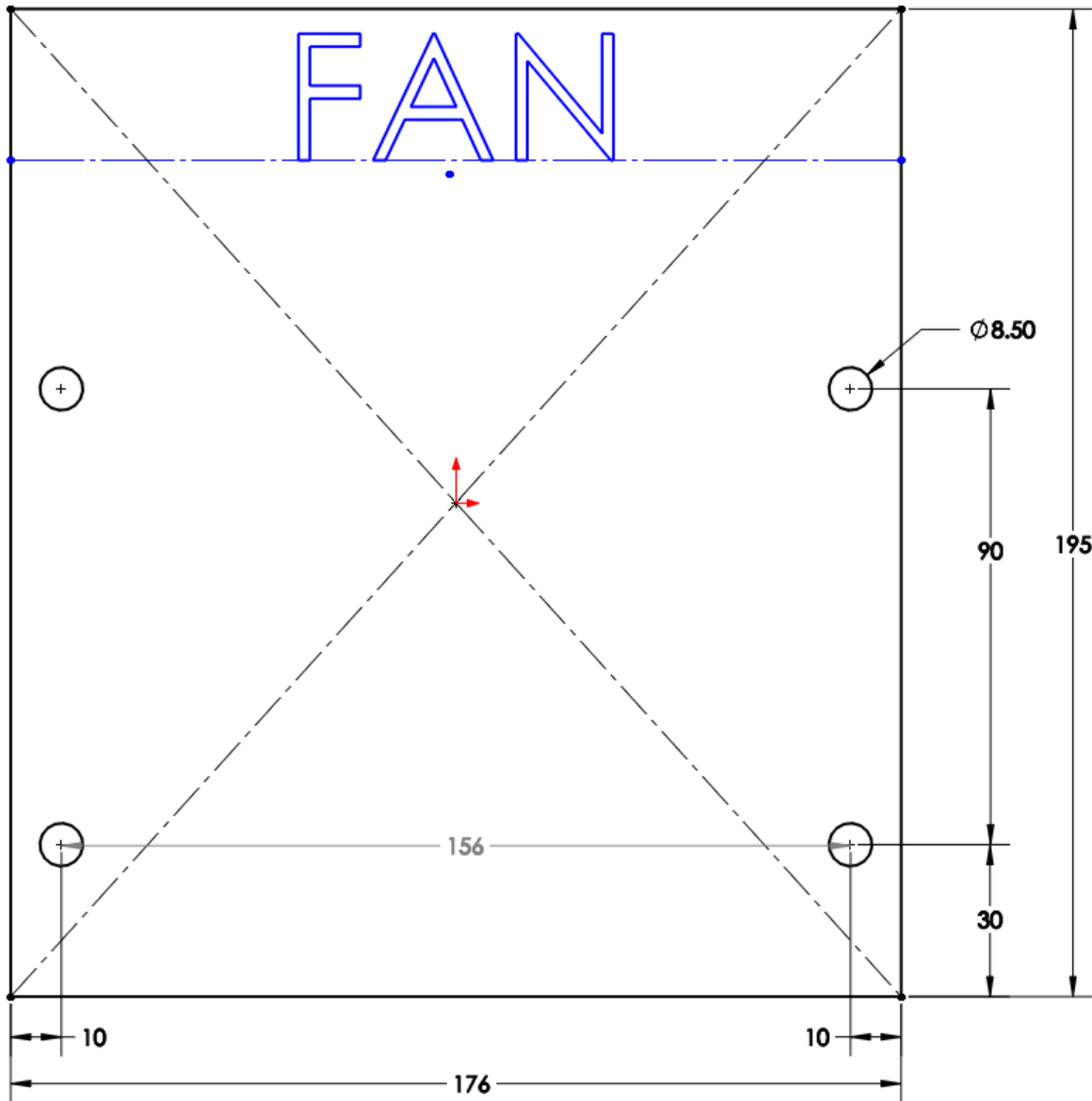

Notice

ElectroMaax reserves the right to make product modifications or discontinue products without notice. Customers are advised to obtain latest written specifications prior to ordering products. Information provided by ElectroMaax is believed to be accurate at the time of its release. Products sales are subject to the ElectroMaax Terms of Sales in force at the time of order acknowledgment. ElectroMaax products are not designed, authorized, or warranted for use in life support devices and systems, or any other critical applications which may involve death, injury, property or environmental damages. Using ElectroMaax products for any critical application is fully at the risk of the customers and their end users and assigns.